



CHAPTER THREE









SERVICE



SAFETY INSTRUCTIONS

The following safety instructions apply to operators and service personnel. Read these instructions before servicing or preparing the Video Game Machine (VGM) for play. Other safety instructions appear throughout this manual.

DEFINITIONS OF SAFETY TERMS

- **DANGER** indicates an imminent hazard. If you fail to avoid this hazard, it **WILL** cause death or serious injury.
- **WARNING** indicates a potential hazard. If you fail to avoid this hazard, it **COULD** cause death or serious injury.
- **CAUTION** indicates a potential hazard. If you fail to avoid this hazard, it **MAY** cause minor or moderate injury. **CAUTION** also alerts you about unsafe practices.
- **NOTE** indicates information of special importance.

	<p>WARNING: TRANSPORTING GAMES. The VGM contains glass and fragile electronic devices. Use appropriate care when transporting. Avoid rough handling when moving the cabinet. Do not move with the power switched on.</p>
	<p>WARNING: DISCONNECT POWER. Always turn the power OFF and unplug the VGM before attempting service or adjustments unless otherwise instructed. Installing or repairing boards with power switched on can damage components and void the warranty.</p>
	<p>WARNING: GROUND GAMES. Avoid electrical shocks! Do not plug in a VGM until you have inspected and properly grounded it. Only plug this game into a grounded, three-wire outlet. Do not use a “cheater” plug, or cut off the ground pin on the line cord.</p>
	<p>WARNING: AVOID ELECTRICAL SHOCKS. The VGM system does not utilize an isolation transformer. Internal cabinet AC is not isolated from the external AC line.</p>
	<p>WARNING: HANDLE FLUORESCENT TUBE AND CRT WITH CARE. If you drop a fluorescent tube or CRT and it breaks, it will implode! Shattered glass can fly eight feet or more from the implosion.</p>
	<p>CAUTION: CHECK POWER SELECTOR, LAMP. Set the 115/230VAC selector on the power supply for the correct line voltage. Check the selector setting before switching on the VGM. Verify that the fluorescent lamp assembly is correct for the local line voltage.</p>
	<p>CAUTION: USE PROPER FUSE. Avoid electrical shock! Replacement fuses must be identically rated. Fuse voltage and current ratings must be identically rated to the original fuse.</p>
	<p>CAUTION: ATTACH CONNECTORS PROPERLY. Be sure board connectors mate properly. If connectors do not slip on easily, do not force them. A reversed connector may damage the VGM and void the warranty. Connector keys only allow a connector to fit one set of pins on a board.</p>

	<p>CAUTION: USE CARE WHEN SHIPPING HARD DISKS.</p> <p>The hard disk drive must be packed in an anti-static bag. When shipping the drive for repair or replacement, pack it in an approved container (P/N 08-8068). Do not stack or drop hard disk drives.</p>
	<p>WARNING: HAZARD TO EPILEPTICS.</p> <p>A very small portion of the population has a condition which may cause them to experience epileptic seizures or have momentary loss of consciousness when viewing certain kinds of flashing lights or patterns that are present in our daily environment. These persons may experience seizures while watching some kinds of television pictures or playing certain video games. People who have not had any previous seizures may nonetheless have an undetected epileptic condition.</p> <p>If you or anyone in your family has experienced symptoms linked to an epileptic condition (e.g., seizures or loss of awareness), immediately consult your physician before using any video games.</p> <p>We recommend that parents observe their children while they play video games. If you or your child experience the following symptoms: dizziness, altered vision, eye or muscle twitching, involuntary movements, loss of awareness, disorientation, or convulsions, DISCONTINUE USE IMMEDIATELY and consult your physician.</p>

SERVICING

Only qualified service personnel should perform maintenance and repairs. The product guidelines apply to all operators and service personnel. Specific notes, cautions, and warnings appear throughout the manual where they apply. We recommend that you read the SAFETY NOTICES section thoroughly before beginning service. **NOTE:** *Always switch off power to the game machine before servicing.*

To service the Marquee...

Refer to *Marquee Service* illustration.

- Switch off the power to the game machine and unplug the AC line cord.
- Remove the tamper-resistant screws used to fasten the marquee to the top of the cabinet.
- Lift the marquee straight out from the cabinet and set aside to expose the opening of the cabinet.
- Perform the desired repair or equipment replacement.
- To reinstall, align the contoured marquee with the contour of the cabinet.
- Fasten in place with the screws provided.

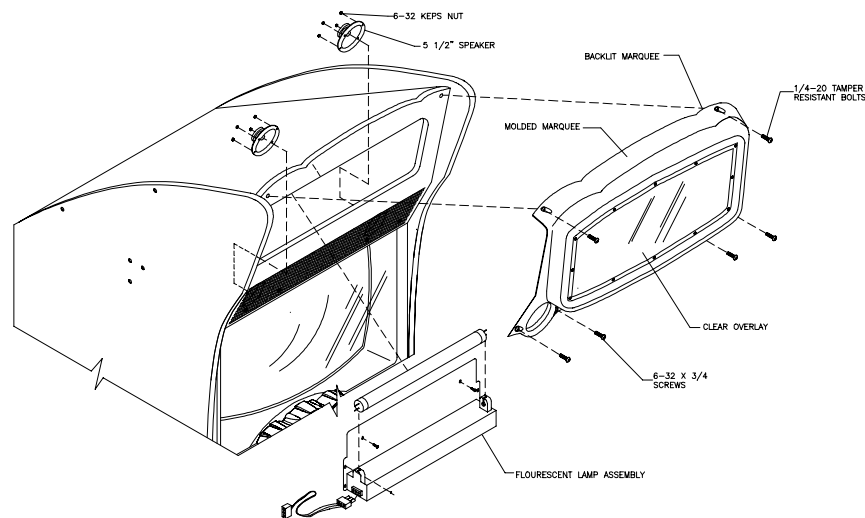

MARQUEE SERVICE

To service the Backlit Marquee ...

Refer to *Marquee Service* illustration.

- Switch off the power to the game machine and unplug the AC line cord.
- Lift open the Marquee Housing. *Refer to service instructions for Marquee.*
- Reach up inside the opening toward the marquee artwork. The marquee artwork and marquee glass is held in place at the top and sides by spacers/brackets fastened with screws.
- Remove the screws from each of the brackets. Set the screws and brackets aside until reinstallation.
- Lift the marquee artwork or marquee glass out of the housing.
- Perform the desired repair or equipment replacement.

To service the Fluorescent Light Assembly...

Refer to *Marquee Service* illustration.

- Switch off the power to the game machine and unplug the AC line cord.
- Lift open the Marquee Housing. *Refer to service instructions for Marquee.*
- Reach up inside the opening in the cabinet and disconnect the power cable from the fluorescent light assembly.
- Loosen, but do not remove the screws fastening the assembly to the cabinet.
- Slide the assembly slightly forward to disengage the keyholes. Lift out the assembly.
- Perform the desired repair or equipment replacement.

To service the Fluorescent Lamp or Starter...

Refer to *Marquee Service* illustration.

- Switch off the power to the game machine and unplug the AC line cord.
- Lift open the Marquee Housing. Refer to *service instructions for Marquee*.
- Reach up inside the opening in the cabinet and remove the fluorescent lamp locks.
- Both the fluorescent tube and the starter require a quarter turn for removal. Grasp the tube or starter, give it a quarter turn and pull it from its socket.
- Carefully place a new starter or tube into the sockets and rotate it a quarter turn to reinstall.
- Reinstall both fluorescent lamp locks. Clean the tube to remove fingerprints and dust.

	<p>WARNING Fluorescent tubes implode on impact when dropped. Use care in handling.</p>
---	---

To service the Cabinet Speakers...

Refer to *Marquee Service* illustration. Speakers are located on the underside of the marquee housing.

- Switch off the power to the game machine and unplug the AC line cord.
- Lift open the Marquee Housing. Refer to *service instructions for Marquee*.
- Reach up inside the opening in the cabinet and disconnect the speaker wires, including the ground strap.
- Remove the nuts on the mounting screws before removing the speakers from the enclosure.
- Perform the desired repair or equipment replacement.
- Carefully reseal the seals upon completing any task in the speaker enclosure.
- Reconnect the wires, including ground. Refer to the Cabinet Wiring Diagram for correct speaker polarity.

NOTE: The speakers are magnetically shielded to prevent video monitor color impurity. Be sure that any replacement speakers are also magnetically shielded.

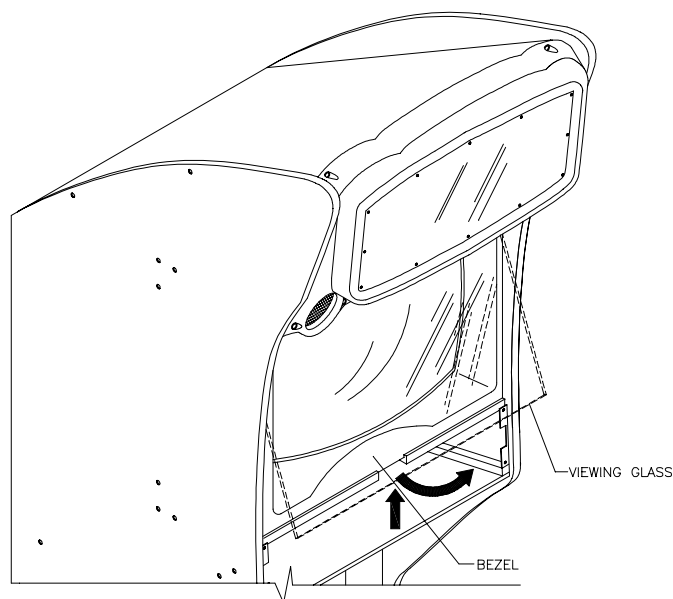

VIEWING GLASS AND BEZEL SERVICE

To service Viewing Glass...

Refer to *Viewing Glass and Bezel Service* illustration.

- Switch off the power to the game machine and unplug the AC line cord.
- Remove the dashboard. *Refer to service instructions for Dashboard.*
- Gently slide the viewing glass up and lift it out of the cabinet. Set the viewing glass aside.
- Perform the desired repair or equipment replacement.
- Clean both the bezel and the viewing glass before reinstallation.



To service Monitor Bezel...

Refer to *Viewing Glass and Bezel Service* illustration.

- Switch off the power to the game machine and unplug the AC line cord.
- Remove the dashboard. *Refer to service instructions for Dashboard.*
- Gently slide the viewing glass up and lift it out of the cabinet. Set the viewing glass aside.
- Grasp the monitor bezel at the bottom and lift it out of the cabinet.
- Perform the desired repair or equipment replacement.
- Clean both the bezel and the viewing glass before reinstallation.

To service the Monitor (CRT)...

We recommend that you read the WARNINGS thoroughly before beginning this procedure.

	<p>CAUTION The video monitor is heavy, with most of the weight toward the front of the assembly. Be sure it is firmly supported as it is moved from the cabinet.</p>
	<p>WARNING The monitor does not require isolation from the AC line voltage in normal operation. When operating outside the cabinet or servicing the monitor on a test bench, ISOLATE THE MONITOR FROM LINE VOLTAGE WITH AN ISOLATION TRANSFORMER.</p>

- Switch off the power to the game machine and unplug the AC line cord.
- Remove the Dashboard, Viewing Glass and Monitor Bezel. *Refer to service instructions for the Dashboard, Viewing Glass and Monitor Bezel.*
- Open the rear cabinet door and disconnect the monitor from the wiring harness and ground wires.
- Remove 4 nuts securing the monitor mounting flanges to the mounting panel.
- Pull the monitor carefully from the cabinet and set aside.
- Perform the desired repair or equipment replacement.

To service the Dashboard...

Refer to *Dashboard Service* illustration.

- Switch off the power to the game machine and unplug the AC line cord.
- Open the rear cabinet door.
- Label and disconnect all dash wiring, including the ground strap.
- Remove the four screws used to fasten the Dashboard to the cabinet.
- Firmly grab the dash and pull it straight out. **NOTE:** *The Dashboard is heavy, with most of the weight concentrated in the center near the Steering Mechanism.*
- Perform the desired repair or equipment replacement.
- To reinstall, line-up the holes on either side of the Dashboard and push straight back.
- Check for pinched wires, and then reconnect dash wiring and ground strap.
- Fasten in place with the screws provided.

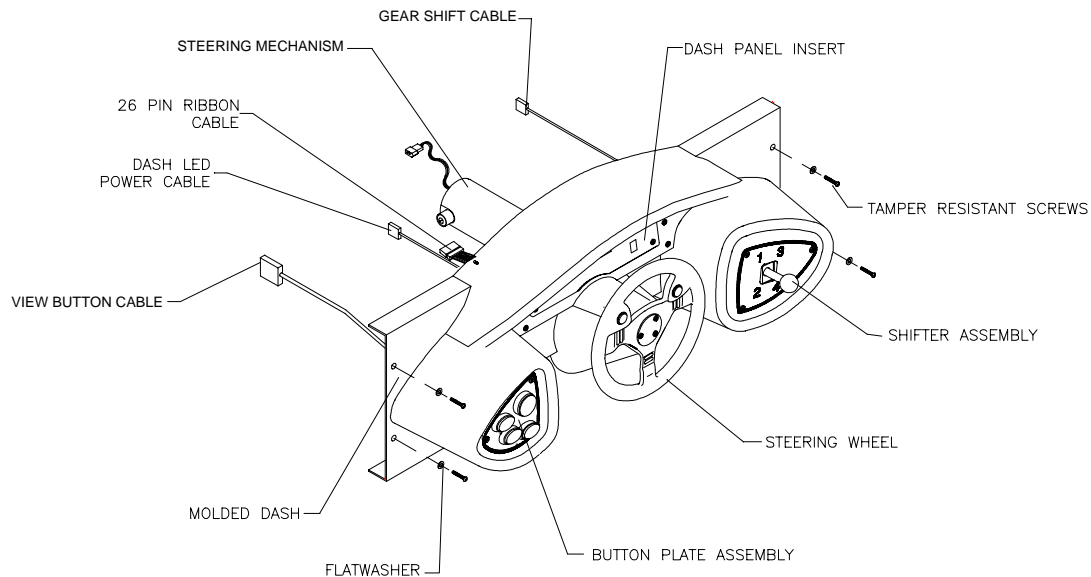
**DASHBOARD SERVICE****To service the Dash Panel Insert ...**

Refer to the *Dashboard Service* illustration.

- Switch off the power to the game machine and unplug the AC line cord.
- Remove the Dashboard. *Refer to service instructions for Dashboard.*
- Remove 4 tamper resistant screws used to fasten the cover to the molded dash and set aside.
- Lift the plastic cover plate off of the PCB and dash.
- Perform the desired repair or equipment replacement. NOTE: *It may also be necessary to remove the Dash PCB. Refer to service instructions for Dashboard PCB.*
- Reinstall and fasten in place with the screws provided.

To service the Dashboard PCB...

Refer to the *Dash PCB Service* illustration.

- Switch off the power to the game machine and unplug the AC line cord.
- Remove the Dashboard. *Refer to service instructions for the Dashboard*
- Remove the steering wheel, shifter plate assembly, and buttons plate assembly. Refer to service instructions for the steering assembly, shifter and buttons.
- Remove 4 tamper resistant screws used to fasten the PCB back plate to the molded dash and set aside.
- Remove the tamper resistant screws used to fasten down the dash panel insert. Lift the insert from the dash.
- Pull out the PCB back plate from the molded dash.
- Remove the ribbon and power cable connections.
- Remove the snaps used to fasten the PCB to the back plate. Lift the PCB off the back plate.
- Perform the desired repair or equipment replacement.
- Connect the ribbon and power cable to a Dashboard PCB. NOTE: *The red stripe on the ribbon cable must be lined up with pin 1 on the PCB, and the black wire on the power cable must line up with pin 1 on the power connection for the Dashboard.*
- Reattach the PCB to the back plate, and then fasten the back plate to the molded dash.
- Check for pinched wires.
- Reinstall the Dashboard and fasten in place with the screws provided.

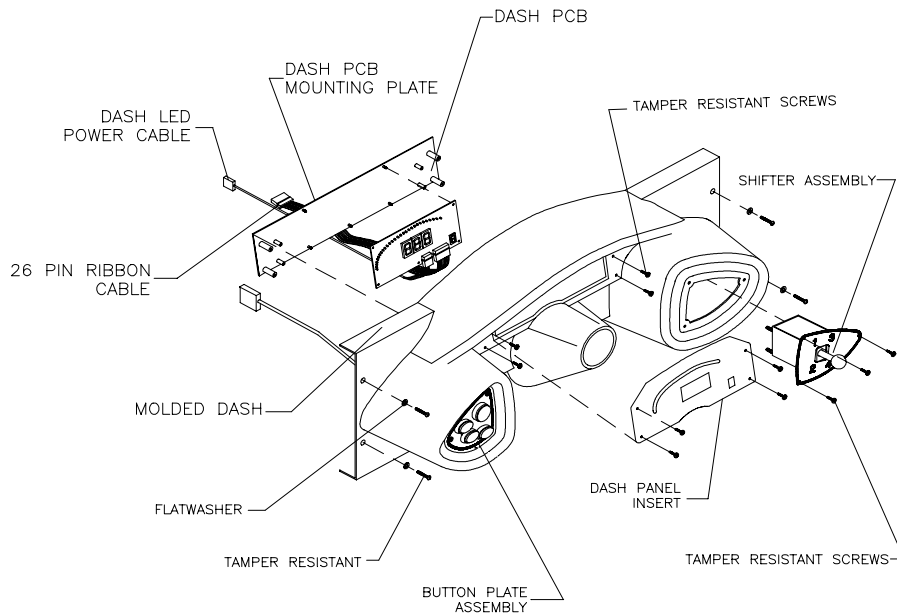

DASH PCB SERVICE

To service Shifter...

Refer to the *General Dashboard Service* illustration.

- Switch off the power to the game machine and unplug the AC line cord.
- Remove the Control Cabinet and the Dashboard. Refer to service instructions for Control Cabinet and Dashboard.
- Remove the tamper resistant screws used to fasten the molded plastic cover on the control cabinet. Lift the cover off of the cabinet and set aside.
- Label and disconnect all wiring.
- Remove the tamper-resistant screws used to fasten both of the faceplates.
- Pull the shifter plate and button plate forward enough to expose the switches. Label and disconnect wiring to switches.
- Lift button assembly completely out of the dash and set aside.
- Remove the bolts used to fasten the shifter enclosure to the dash plate.
- Lift enclosure from dash plate. Label and disconnect wires.
- Perform the desired repair or equipment replacement.
- Reconnect wires and reinstall shifter.
- Check for pinched wires.
- Fasten the faceplate with the screws provided.

To service Start and View Buttons...

- Switch off the power to the game machine and unplug the AC line cord.
- Remove the 3 tamper-resistant buttons used to fasten the faceplate.
- Pull the plate forward enough to expose the switches.
- Label and disconnect the wiring.
- Lift assembly completely out of the dash and set aside.
- Perform the desired repair or equipment replacement.
- Reconnect wires and reinstall buttons.
- Check for pinched wires.
- Fasten the faceplate with the screws provided.

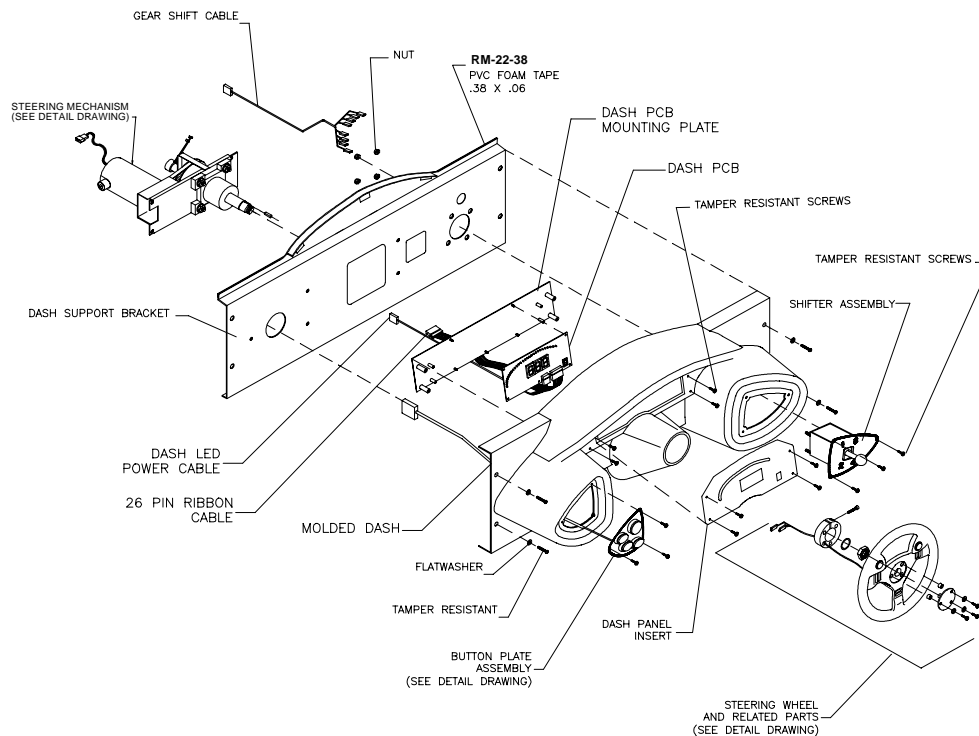

GENERAL DASHBOARD SERVICE

To service Steering Assembly...

- Refer to the *General Dashboard Service* illustration.
- Switch off the power to the game machine and unplug the AC line cord.
- Remove the Dashboard. *Refer to service instructions for Dashboard.*
- Remove 6 screws used to fasten the cover plate to the center of the steering wheel. Remove the cover plate and set aside.
- Remove the 3 screws used to fasten the wheel hoop to the shaft. Pull the wheel hoop off of the dashboard. Disconnect the harness for the buttons on the steering wheel.
- Remove 4 flange nuts holding the motor shield, motor and shaft to the wheel assembly (shield not required on all cabinets).
- Slide the motor and the shaft off of the assembly.
- Perform the desired repair or equipment replacement.
- Reinstall and fasten all items in place with the screws provided.

While the steering mechanism is exposed, inspect the belt for splits in the rubber or other signs of wear at the edges of the teeth. Install a new belt if necessary following the instructions below.

To service Steering Belt...

- Loosen four mounting nuts for the motor bracket.
- Tighten the tension-adjust bolt only until there is no belt deflection, then loosen the bolt one full turn and tighten the four nuts.
- Reattach the mechanism and recalibrate the assembly.

IMPORTANT: Apply removable anaerobic adhesive thread lock (Loctite Blue 242 or equivalent) and torque set screw to seven to nine ft.-lbs. (84 to 108 in.-lbs.) if it was loosened.

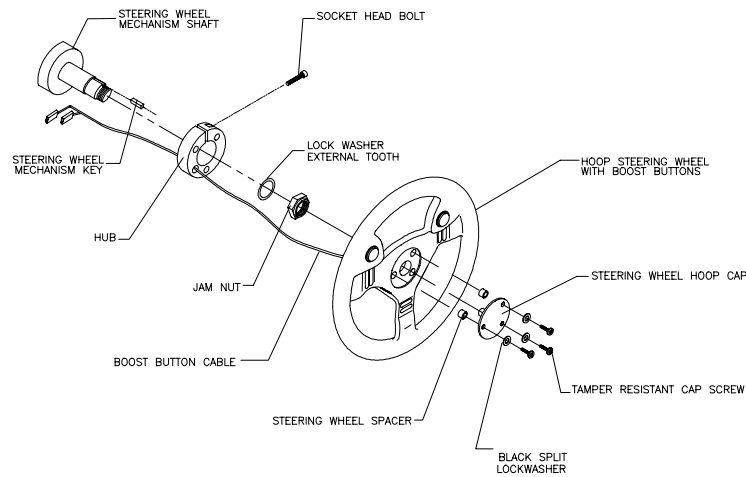

STEERING WHEEL HOOP SERVICE

To service Boost Buttons on the Steering Wheel Hoop...

Refer to the *Steering Wheel Hoop Service* illustration.

- Switch off the power to the game machine and unplug the AC line cord.
- Remove the screws used to fasten the wheel hoop cap to the steering wheel. Lift of the hoop cap off and set it aside with the hardware for reuse later.
- Lift out the steering wheel spacers.
- Gently pull the steering wheel forward enough to expose the boost button cable connector.
- Unplug the boost button cable. Remove the steering wheel completely from the dashboard.
- Turn the steering wheel over to observe the rear side of the wheel hoop. Remove the tamper resistant screws used to fasten the rear cover to the steering wheel hoop. Lift the cover off and set aside with the hardware for reuse later.
- Use a desoldering tool coupled with a soldering iron to remove the solder used to attach the cable wires to the button's switch. **NOTE:** Use caution when performing this step to avoid becoming burned by liquefied solder and /or to avoid melting plastic parts.
- Allow the area surrounding the switch and button to cool properly before proceeding.
- Unscrew the nut on the button. Lift the button out of the steering wheel hoop.
- Perform the desired repair or equipment replacement.
- Be sure to solder the cable wires to the button's switch when reinstalling a button(s).
- Reinstall and fasten all items in place with the screws provided.

To service Lower Cabinet Speaker...

This speaker is located just above the pedal assembly.

- Switch off the power to the game machine and unplug the AC line cord.
- Unlock and remove the rear cabinet door.
- Label and disconnect wiring, including the ground strap, to Board assemblies attached to the electronics shelf.
- Remove the screws used to fasten the electronics shelf inside the cabinet, then remove the shelf and set it aside.
- Locate the speaker. Remove the nuts on the mounting screws before removing the speaker from the enclosure.
- Perform the desired repair or equipment replacement.
- Carefully reseal the seals upon completing any task in the speaker enclosure.
- Reconnect the wires, including ground. Refer to the Cabinet Wiring Diagram for correct speaker polarity.

To service Pedal Assembly...

- Switch off the power to the game machine and unplug the AC line cord.
- Adjust the seat to the maximum rear position.
- Remove 4 tamper resistant screws used to fasten the Pedal assembly to the cabinet. **NOTE:** *Due to the weight of the pedal assembly it may slide or abruptly jerk out of the opening once all screws are loosened and/or removed.*
- Pull the assembly forward enough to expose wiring.
- Carefully note the orientation of the cable wiring. Label and disconnect wiring, including ground.
- Perform the desired repair or equipment replacement.
- Reinstall pedal assembly and reconnect wiring, including ground.
- Align the holes for the screws and fasten in place with the hardware provided.

To service Coin Meter...

- Switch off the power to the game machine and unplug the AC line cord.
- Unlock the cash door and swing it open. Remove the cash tubs.
- The meter is located on a plate at the vault bottom. Remove the screws and lift the plate just enough to disconnect the meter wires from the harness.
- Record the meter count before testing or replacement.
- Perform the desired repair or equipment replacement.

To service Coin Mechanism...

- Switch off the power to the game machine and unplug the AC line cord.
- Unlock the coin door and swing it open.
- Unlatch and remove each coin mechanism separately to clean or replace with a different type. Ensure mechanism seats fully in the holder upon reinstallation.
- Close and lock the release latch, then close the door.
- Turn on the game and change the mechanism setup, then test known good and bad coins to verify operation.

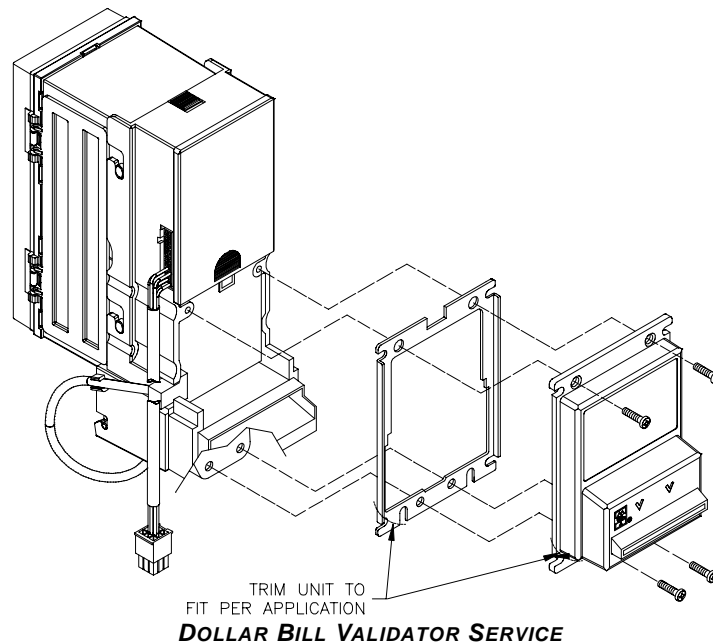

To service Dollar Bill Validator...

(Use MARS AE2411-U3 UL recognized currency changer)

Dollar bill validators or other currency acceptors may be installed in games that are manufactured with the additional wiring connector.

- Switch off the power to the game machine and unplug the AC line cord.
- Unlock the coin door and swing it open. Read the label affixed to the door for additional information.
- Disassemble the validator and remove material to permit it to fit inside the coin door as illustrated then reassemble unit.

To service PCB Board Assemblies...

- Switch off the power to the game machine and unplug the AC line cord.
- Unlock and remove the rear door.
- Remove the screws used to fasten the hinged, metal cage covering the PCB Assembly.
- Open the cover, which is hinged along the bottom edge, to expose the PCB assembly.
- Carefully note the orientation of the JAMMA connector and the other cables. Extract the harness and other cables from the board connectors.
- Remove the mounting screws from the desired circuit board assembly. Lift the board out of the cabinet and set in a safe place. Use anti-static bags and protective containers from new parts for storage if not reinstalled immediately.
- Perform the desired repair or equipment replacement.
- Be certain to reinstall the perforated cover so that it seals against the metal plate.



CAUTION

Discharge any static electricity built up in your body by touching the chassis for the power supply. Do this BEFORE touching or handling the electronic assemblies.

To service Wheel Driver Board Assembly...

- Switch off the power to the game machine and unplug the AC line cord.
- Unlock and remove the rear door.
- Remove the screws used to fasten the hinged, perforated metal cage covering the PCB Assembly.
- Open the cage, which is hinged along the bottom edge, to expose the PCB assembly.
- Carefully note the orientation of the cables. Extract the harness and other cables from the board connectors.
- Remove the wheel driver board assembly mounting screws. Lift the board out of the cabinet and set in a safe place. Use anti-static bags and protective containers for storage if not reinstalled immediately.
- Perform the desired repair or equipment replacement.
- Be certain to reinstall the metal cover so that it seals against the metal cage.

To service the Main Boot, PIC or Sound ROM...

The ROM (Read Only Memory) circuits contain the computer operating instructions for the game. The Main Boot ROM is located on the Mango PCB; the sound ROM is located on the Vegas SIO PCB; the PIC chip is located on the Vegas SIO PCB.

Memory devices are especially sensitive to static charges. Use grounding precautions when handling these parts.

- Switch off the power to the game machine and unplug the AC line cord.
- Unlock and remove the rear door.
- Remove the screws used to fasten the hinged, metal cage covering the desired PCB Assembly.
- Open the cover, which is hinged along the bottom edge, to expose the PCB assembly.
- Carefully note each IC position, and then remove using a chip extraction tool.
- To install memory circuits, orient a chip over the corresponding socket and press firmly to seat pins. *Do not force.*

**CAUTION**

Discharge any static electricity built up in your body by touching the chassis for the power supply. Do this **BEFORE** touching or handling the electronic assemblies

To service the Battery...

- Switch off the power to the game machine and unplug the AC line cord.
- Unlock and remove the rear door.
- Remove the screws used to fasten the hinged, metal cage covering the PCB Assembly.
- Open the cage, which is hinged along the bottom edge, to expose the PCB assembly.
- Locate the battery on the Vegas SIO Board assembly, and then remove using a chip extraction tool.
- To install a battery, orient a battery over the corresponding socket and press firmly to seat. **NOTE:** Do not force; the battery is notched and will only fit in the socket one way.

To service an Auxiliary Board Assembly...

- Switch off the power to the game machine and unplug the AC line cord.
- Unlock and remove the rear door.
- Remove the screws used to fasten the hinged, metal cage covering the PCB Assembly.
- Open the cover, which is hinged along the bottom edge, to expose the PCB assembly.
- Carefully note the orientation of the cables. Extract the harness and other cables from the board connectors.
- Remove the assembly mounting screws. Lift the board out of the cabinet and set in a safe place. Use anti-static bags and protective containers for storage if not reinstalled immediately.
- Perform the desired repair or equipment replacement.
- Be certain to reinstall the metal cover so that it seals against the metal cage.

To service the Power Supply...

- Switch off the power to the game machine and unplug the AC line cord.
- Unlock and remove the rear cabinet door.
- Unplug the IEC AC connector from the rear of the supply and the DC connector from the front.
- Remove the two front and two rear screws from the supply, then lift it off of the power chassis. Note voltage setting.
- Perform the desired repair or equipment replacement.
- Be sure to set the voltage switch to the correct value prior to reinstallation.
- Set the supply on the power chassis and align the mounting holes. Install the four screws and the two power connectors.

To service the Transformer...

- Switch off the power to the game machine and unplug the AC line cord.
- Unlock and remove the rear door.
- If the power to the Video Game Machine (VGM) was only recently disconnected, the transformer may still be warm. Allow the transformer to cool completely before handling.
- Label and disconnect all wiring, including ground.
- Remove the screws used to fasten the transformer to the base of the cabinet.
- Perform the desired repair or equipment replacement.

**DANGER**

High voltage present. Exercise extreme caution while servicing transformer.

To service Fan Assembly...

- Switch off the power to the game machine and unplug the AC line cord.
- Unlock and remove the rear door.
- Remove the perforated metal cover to expose the fan assembly and set aside.
- Unplug the fan power connector from the wiring.
- Remove the screws used to fasten a fan down and then lift fan out.
- Perform the desired repair or equipment replacement.

To service Speakers in Head Rest...

Refer to the *Seat Pedestal Service* illustration.

- Switch off the power to the game machine and unplug the AC line cord.
- Remove the tamper resistant screws from the speaker grille.
- Remove the tamper resistant screws used to fasten the speaker plate to the seat and pull forward.
- Label and disconnect wires, including ground.
- Remove the nuts used to fasten the speaker to the plate and remove speaker(s).
- Perform desired repair or equipment replacement.
- Reinstall the speaker(s) to the speaker plate and reattach wiring, including ground. Attach the speaker plate to the seat.
- Reinstall speaker grille and fasten in place with hardware provided.

To service Speaker in Seat Back...

Refer to the *Seat Pedestal Service* illustration.

- Switch off the power to the game machine and unplug the AC line cord.
- Remove the tamper resistant screws used to fasten the grille to the seat and pull forward.
- Label and disconnect wires, including ground.
- Remove 4 Phillips head screws used to fasten the speaker to the seat and remove speaker.
- Perform desired repair or equipment replacement.
- Reinstall speaker and reattach wiring, including ground.
- Reinstall speaker grille and fasten in place with hardware provided.

To service the Seat Slide Assembly...

Refer to the *Seat Pedestal Service* illustration.

- Switch off the power to the game machine and unplug the AC line cord.
- Disconnect the Seat Assembly from the cabinet by removing the tamper resistant screws used to fasten the assembly to the slide rails in the cabinet.
- Slide the Seat Assembly halfway back along the rails to expose wiring.
- Disconnect the speaker cable and slide the seat the rest of the way off the rails.
- Remove 3 tamper resistant screws from each side of the seat mounting plate. Lift the seat and mounting plate assembly off the pedestal and set aside.
- Slide the seat assembly forward, and remove the two tamper resistant screws from the rear of the metal panel on top of the pedestal assembly.
- Slide the seat assembly backward and remove the two tamper resistant screws from the front of the metal panel.
- Lift the metal panel out of the pedestal base and turn the unit over.
- Remove the four nuts holding the metal panel to the slide assembly. Set the metal panel aside and slide assembly is exposed.
- Perform the desired repair or equipment replacement.
- Reinstall by performing the steps in reverse and fasten in place using the hardware provided.

IMPORTANT: Apply removable anaerobic adhesive thread lock (Loctite Blue 242 or equivalent) and torque each bolt to seven to nine ft.-lbs. (0.7 to 1.0 Nm) if it was loosened (see illustration).

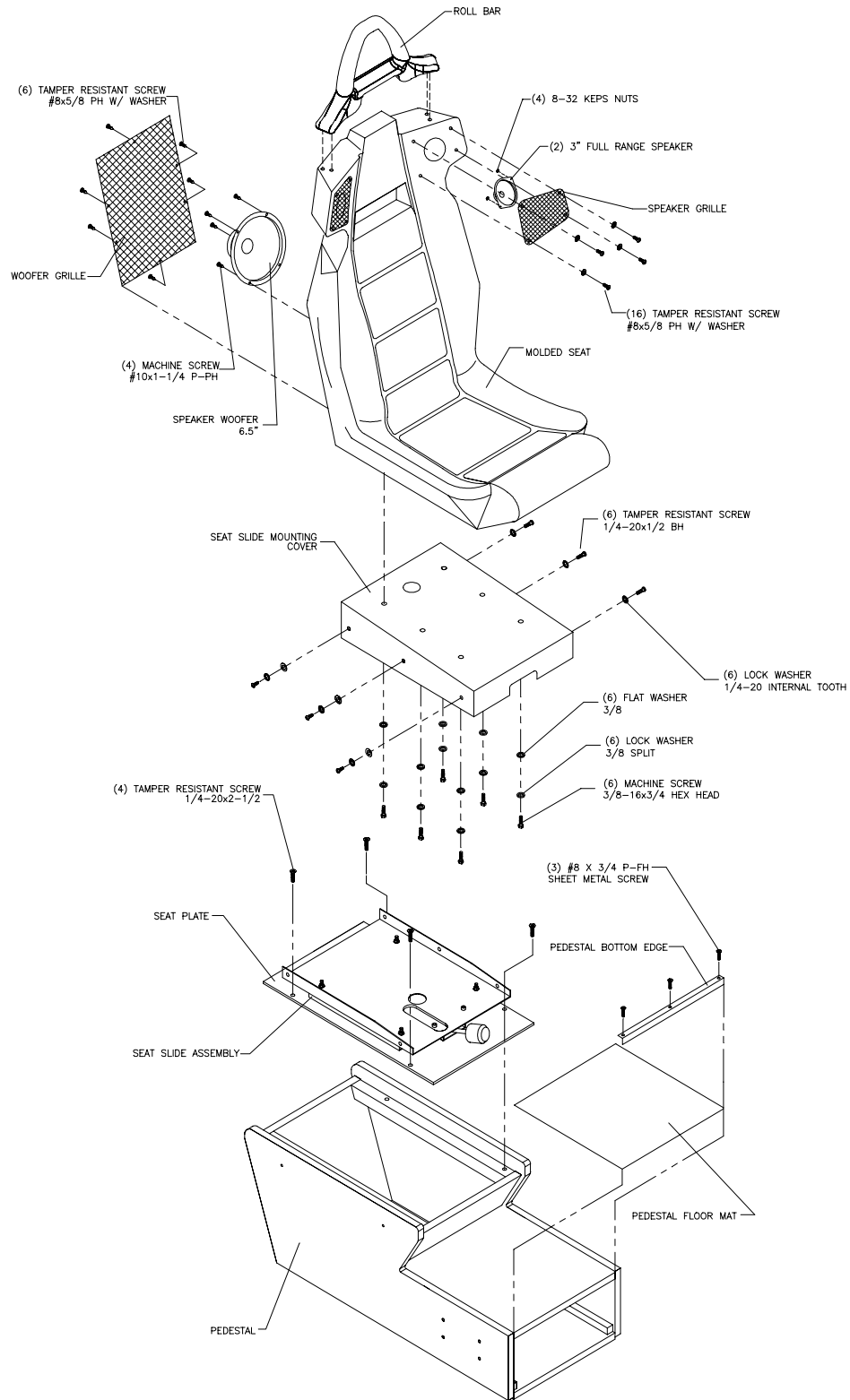

SEAT PEDESTAL SERVICE

To service the Seat Assembly...

The Seat Assembly includes the pedestal base. Refer to the Seat Pedestal Service illustration.

- Switch off the power to the game machine and unplug the AC line cord.
- Disconnect the Seat Assembly from the cabinet by removing 8 tamper resistant screws used to fasten the assembly to the slide rails in the cabinet.
- Slide the Seat Assembly halfway back along the rails to expose wiring.
- Disconnect the speaker cable and slide the seat the rest of the way off the rails.
- Remove 3 tamper resistant screws from each side of the seat mounting plate. Lift the seat and mounting plate assembly off the pedestal.
- Place the seat on its back, on a flat surface. Perform the desired repair or equipment replacement.
- Reinstall using the hardware provided.

IMPORTANT: Apply removable anaerobic adhesive thread lock (Loctite Blue 242 or equivalent) and torque each bolt to seven to nine ft.-lbs. (0.7 to 1.0 Nm) if it was loosened (see illustration).